

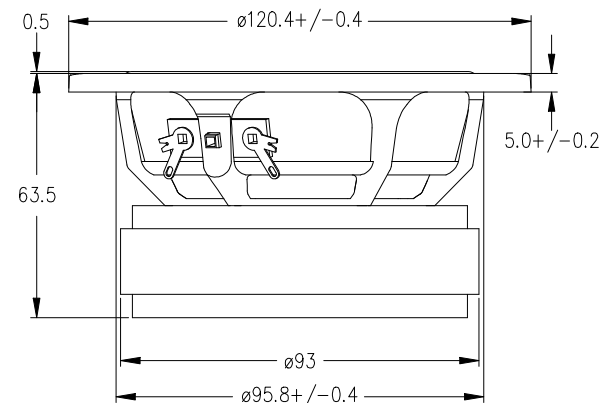

WOOFER W12CY001 E0021

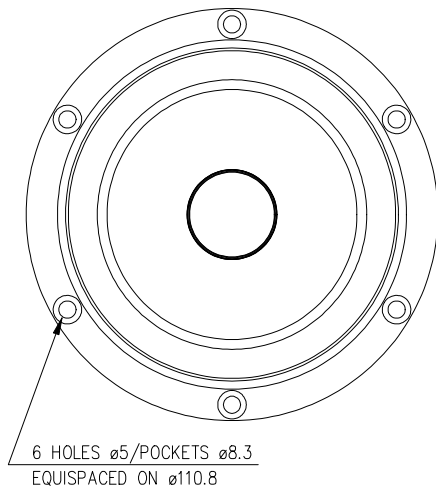

The W12CY002 is a 12cm (4,5") cone driver developed for use as a high fidelity woofer/midrange unit. The extremely stiff, yet light cone gives tremendous bass precision and midrange detail.

SPECIAL FEATURES:

Precision cast and surface treated magnesium cone coupled to a natural rubber surround showing no sign of midrange (edge) resonances.

Perfectly matched moving parts for a smooth, extended frequency response.

Heavy copper rings mounted above and below the T-shaped pole piece, to reduce non linear and modulation distortion and increase overload margin.

An extra large magnet system for good sensitivity and transient response. Copper plating of the top and bottom plates and a solid copper phase plug, which enhance the performance of the copper rings and improve heat conduction away from the pole piece.

Gold plated terminals mounted on a stiff bakelite plate to reduce contact resistance and improve reliability.

Extremely stiff and stable injection moulded metal basket to keep the critical components in perfect alignment. Large windows in the basket both above and below the spider to reduce sound reflection, air flow noise and cavity resonance to a minimum.

NOMINAL IMPEDANCE	8 Ohms	VOICE COIL RESISTANCE	5.6 Ohms
RECOMMENDED FREQUENCY RANGE	60-3500 Hz	VOICE COIL INDUCTANCE (EQUIVALENT)	0.3 mH
SHORT TERM MAXIMUM POWER *	200 W	FORCE FACTOR	5.6 N/A
LONG TERM MAXIMUM POWER*	70 W	FREE AIR RESONANCE	46 Hz
CHARACTERISTIC SENSITIVITY (1W, 1m)	85 dB SPL	MOVING MASS	7.0 g
OPERATING POWER (96 dB SPL, 1 m)	12.5 W	AIR LOAD MASS IN IEC BAFFLE	0.2 g
VOICE COIL DIAMETER	26 mm	SUSPENSION COMPLIANCE	1.7 mm/N
VOICE COIL HEIGHT	12 mm	SUSPENSION MECHANICAL RESISTANCE	1.0 Ns/m
AIR GAP HEIGHT	6.0 mm	EFFECTIVE PISTON AREA	50 sq.cm
LINEAR COIL TRAVEL (p-p)	6.0 mm	VAS	5.8 Litres
MAXIMUM COIL TRAVEL (p-p)	9 mm	QMS	2.2
MAGNETIC GAP FLUX DENSITY	1.10 T	QES	0.37
MAGNET WEIGHT	0.42 Kg	QTS	0.32
TOTAL WEIGHT	1.21 Kg		

* IEC 268-5

Response curve recorded in anechoic chamber (Free-field, 4 pi radiation) with 0.5m microphone distance. The loudspeaker is mounted in a closed box of 2.5 l net. volume

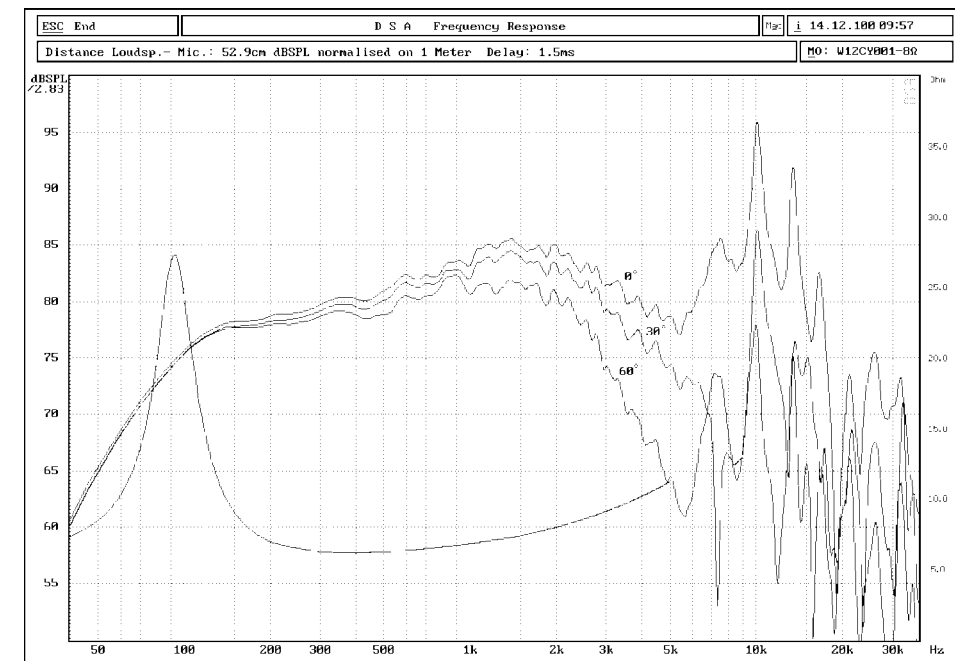

Distortion on axis in % between 25 and 2000 Hz at operating power.

